

DESIGN NOTES

Power Solutions for the Device Bay – Design Note 197

Ajmal Godil

“Device Bay” is an industry specification defining a mechanism for easily adding and upgrading PC peripheral devices to a live system without opening the chassis or shutting off the power. This requires Hot Swap™ capability for the Device Bay to ensure the integrity of users’ data and applications. For example, a CD-R drive could be added to provide a large storage medium for digital imaging or a DVD drive could be added to enable DVD video playback. The Device Bay specification applies to all classes of computers, including desktop, mobile, home and server computers. Device Bay comes in three form factors:¹ DB32, DB20 and DB13. The DB32 is designed for desktops with a maximum power consumption of 25W, DB20 is designed for laptops and desktops with a maximum power consumption of 4W and DB13 is designed for laptops with a maximum power consumption of 4W.

Device Bay Power Requirements

According to the Device Bay Interface specification,¹ Revision 0.85, the DB32, DB20 and DB13 form factors all require an identification voltage (Vid_3.3V), which needs to be provided by the host system. It is recommended that this voltage be increased slowly when the device is inserted into the system, because the supply bypass capacitors on the device can draw huge transient currents from the system power supply as they charge. The transient currents can cause permanent damage to the connector pins and glitches on the system supply. These glitches may force other boards in the system to reset. The device uses the identification voltage to power the 1394 bus or the USB interface. Additionally, the DB32 form factor needs 12V, 5V and 3.3V supplies. The DB20 and

DB13, on the other hand, only need 5V and 3.3V supplies. It is recommended that these supply voltages also increase slowly to minimize current spikes. Figure 1 shows a block diagram of a circuit that controls the rise time of the various voltage sources on the device side and the system side for the DB32 form factor. The maximum allowable currents for various Device Bay form factors are as follows:

Table 1. Maximum Allowable DB32 Device Current

VOLTAGE	TRANSIENT <100 μ s (A)	PEAK CURRENT 100 μ s to 30s (A)	ELECTRICAL CONTINUOUS CURRENT 30s to 300s ¹ (A)	THERMAL CONTINUOUS CURRENT >300s ¹ (A)
Vid_3.3V	0.91	0.45	0.45	0.45
12V	5	3.75	2.5	2
5V	4	3	2	2
3.3V	7	5.25	3.5	3.5

Table 2. Maximum Allowable DB20 and DB13 Device Current

VOLTAGE	TRANSIENT <100 μ s (A)	PEAK CURRENT 100 μ s to 30s (A)	ELECTRICAL CONTINUOUS CURRENT 30s to 300s ¹ (A)	THERMAL CONTINUOUS CURRENT >300s ¹ (A)
Vid_3.3V	0.91	0.45	0.45	0.45
5V	2	1.6	0.8	0.8
3.3V	3.03	2.42	1.21	1.21

LT, LTC and LT are registered trademarks of Linear Technology Corporation. Hot Swap is a trademark of Linear Technology Corporation.

¹Device Bay Interface Specification, Revision 0.85, February 6, 1998.

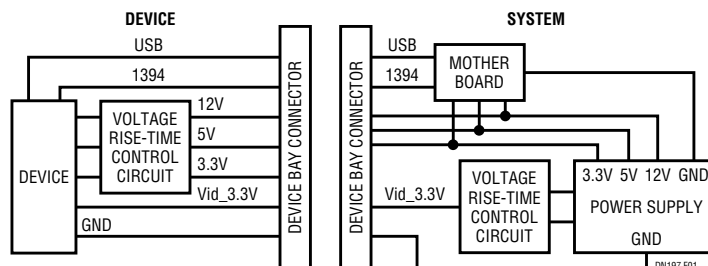

Figure 1. Block Diagram for the Device Bay

Power Solution for Vid_3.3V on the System Side

Figure 2 shows the power solution for DB32, DB20 and DB13's Vid_3.3V supply using the LTC[®]1422. The LTC1422 is an 8-pin Hot Swap controller that allows safe insertion of an external peripheral into the Device Bay slot. By increasing the voltage on the MOSFET Q1's gate at a controlled rate, the transient surge current drawn by the device's bulk capacitor is limited to a safe value when the device is connected to the bay.

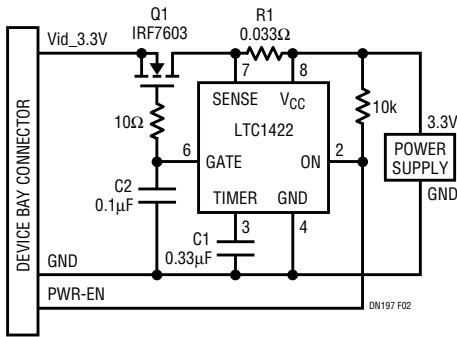

Figure 2. Vid_3.3V Supply Solution for DB32, DB20 and DB13 Form Factors

When power is first applied to the bay system, the gate of Q1 is pulled low. After the PWR-EN pin is released from GND by the Device Bay connector and the software controlled PWR_CTL bit, the voltage on the LTC1422 ON pin changes to a logic high. After the ON pin is held high for at least one timing cycle ($t_1 = 1.232 \cdot C1/2\mu A$), the charge pump turns on. The voltage at the gate begins to rise with a slope equal to $10\mu A/C2$, where C2 is the external capacitor connected between the GATE pin and GND. The rise time for the supply is equal to $3.3V \cdot C2/10\mu A$ (Figure 3).

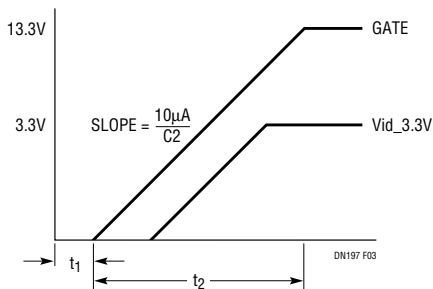

Figure 3. Supply Turn On

The LTC1422 features an electronic circuit breaker function that protects against short circuits or excessive currents from the supply. By placing a sense resistor, R1, between the supply input and the SENSE pin, the circuit

breaker will be tripped whenever the voltage across the sense resistor is greater than 50mV for more than 10μs. The sense resistor should be sized to allow 150% of the maximum load current to flow before the circuit breaker trips. Therefore, by choosing $R1 = 0.033\Omega$, approximately 1.5A (versus Device Bay specification of 0.91A) would flow into the device before the circuit breaker trips. When the circuit breaker trips, the GATE pin is immediately pulled to GND and the external MOSFET Q1 is quickly turned off.

Power Solutions for DB32, DB20 and DB13 Form Factors on the Device Side

Figure 4 shows the application circuit for DB32, DB20 and DB13 form factors using the LTC1422 on the device side. These circuits operate in the same fashion as the circuit in Figure 2, except that a single LTC1422 is used to control the gates of multiple MOSFETs to allow the respective voltage supplies to rise simultaneously. Also, since a single LTC1422 controls multiple supplies, the circuit breaker feature in Figure 4 has been eliminated by shorting Pins 7 and 8 together.

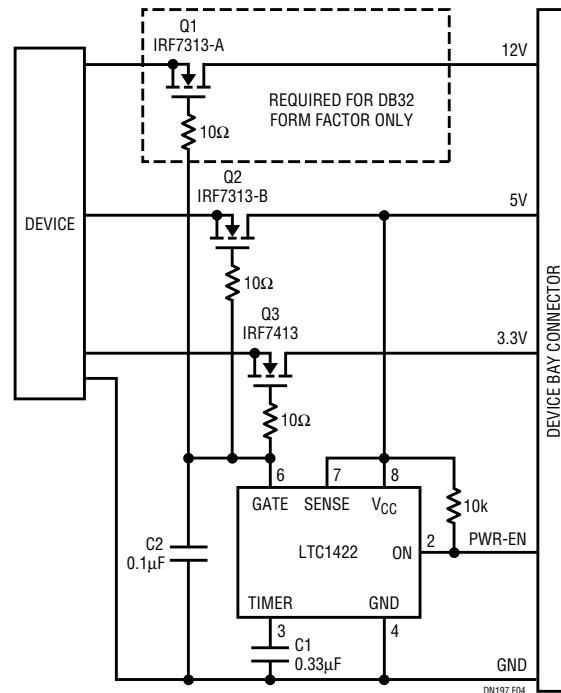

Figure 4. Device Side Voltage Ramp-Up Circuit for DB32, DB20 and DB13 Form Factors

For literature on our Hot Swap Controllers, call **1-800-4-LINEAR**. For applications help, call (408) 432-1900, Ext. 2593